

Howard B. Mattlin Middle School

Incoming Grade 8

Parent Transition Meeting

January 12, 2016

Meeting Overview

- 8th Grade Transition - Student Perspective
- Availability of Core and Special Area Classes
- Options for Acceleration
- Course Recommendations and Self Selection
- Overview of Various Student Programs
- Options for Additional Support During Zero and 9th Period

Chris Donarummo, Principal

Tom Schwartz, Assistant Principal (Grades 5 & 7)

Cathryn Riley, Guidance Counselor

Dylan Lomelo, School President

7th to 8th Grade Transition
Student Perspective

Dylan Lomelo

Howard B. Mattlin Middle School
President

Overview of Courses Available

Core Area Subjects: *(Every Day For One Period)*

- English
- Social Studies
- Science
- Math
- World Languages

Special Area Subjects:

(Every Other Day All Year or Every Day for a Semester)

- Physical Education
- Health
- Technology
- Art

Acceleration Options

➤ Earth Science + Lab

Replaces Science 8 and includes a lab every other day

➤ Algebra 1

Replaces Math 8

➤ Studio Art

Replaces Art 8

All accelerated courses are credit bearing and will appear on your child's high school transcript.

Accelerated Courses Selection Process

Integrated Algebra

- Placement determined when students enter grade 7
- Math 7 Accelerated is a pre-requisite

Earth Science

- Currently enrolled in Math 7 Accelerated
- Quarter grades in Math 7 and Science 7

Studio Art

- Assessment to be administered to evaluate student's art skills

How will I know the recommendations for my child?

Course Verification Forms

- All parents/guardians will receive printed course verification forms in the mail on or about **March 7, 2016**
- Forms must be signed and returned to the Guidance Office at Mattlin Middle School by **April 1, 2016**
- Parents have the opportunity to discuss the recommendation with the teacher and guidance counselor
- All information will also be available on the Portal

Course Verification Form

STUDENT NAME

Student Number: XXXXXXXX

Grade: 08

Requested Courses:

806 LUNCH 8

812 ENGLISH 8

822 MATH 8

830 SOCIAL STUDIES 8

805 PHYS ED 8

850 SPANISH 1R

903 STUDIO ART

844 HEALTH 8

403-1 EARTH SCI-R+LAB

403-2 EARTH SCI-R-LAB

Parent/Guardian Signature _____

Date _____

What is Self-Selection?

- Opportunity to enroll in an accelerated course when not recommended
 - ✓ Conversation with the student
 - ✓ Conversation with teacher and guidance counselor
- What is the process for self-selection?
 - ✓ Complete and return a Self-Selection form for each accelerated course
 - ✓ Form must be returned by April 1, 2016



Excellence in Education

HOWARD B. MATTLIN MIDDLE SCHOOL
SELF-SELECTION FORM
2016-2017



Student's First Name

Student's Last Name

Grade in 2015-2016

I would like to self-select my child into the accelerated course circled below. I realize that this was not the recommended course for my child for the upcoming school year. I am also aware that if my child does not perform well in this course and needs a change in placement during the school year, this could significantly impact his/her schedule.

Accelerated Course Offerings – Grade 7

722 Math 7 Accelerated

Accelerated Course Offerings – Grade 8

301 Algebra 1

403-1 Earth Science + Lab

801/903 Studio Art

Parent's Signature

Date

Student's Signature

This form must be returned to the guidance office
no later than Friday, April 1, 2016.

Mathematics

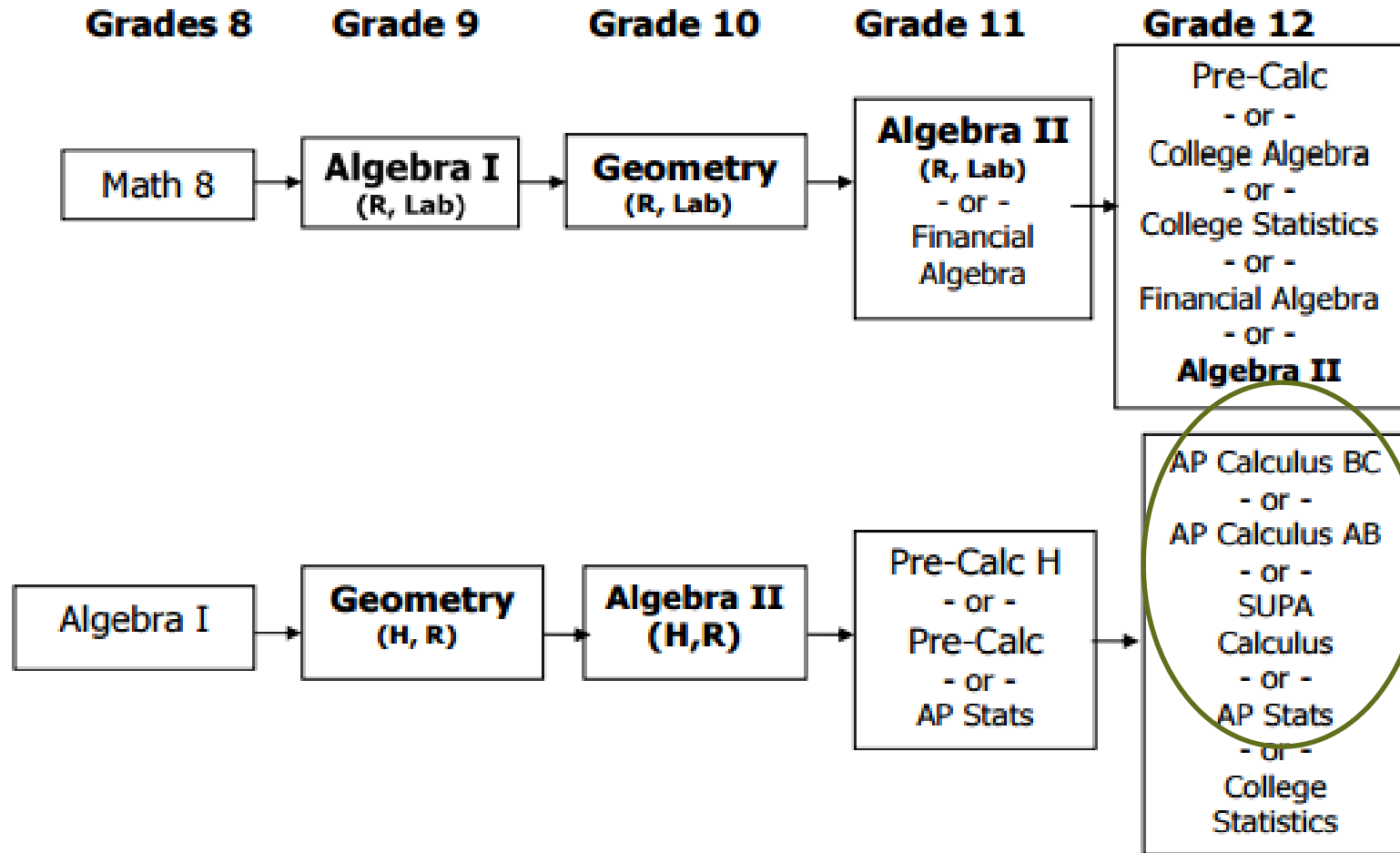

SCIENCE

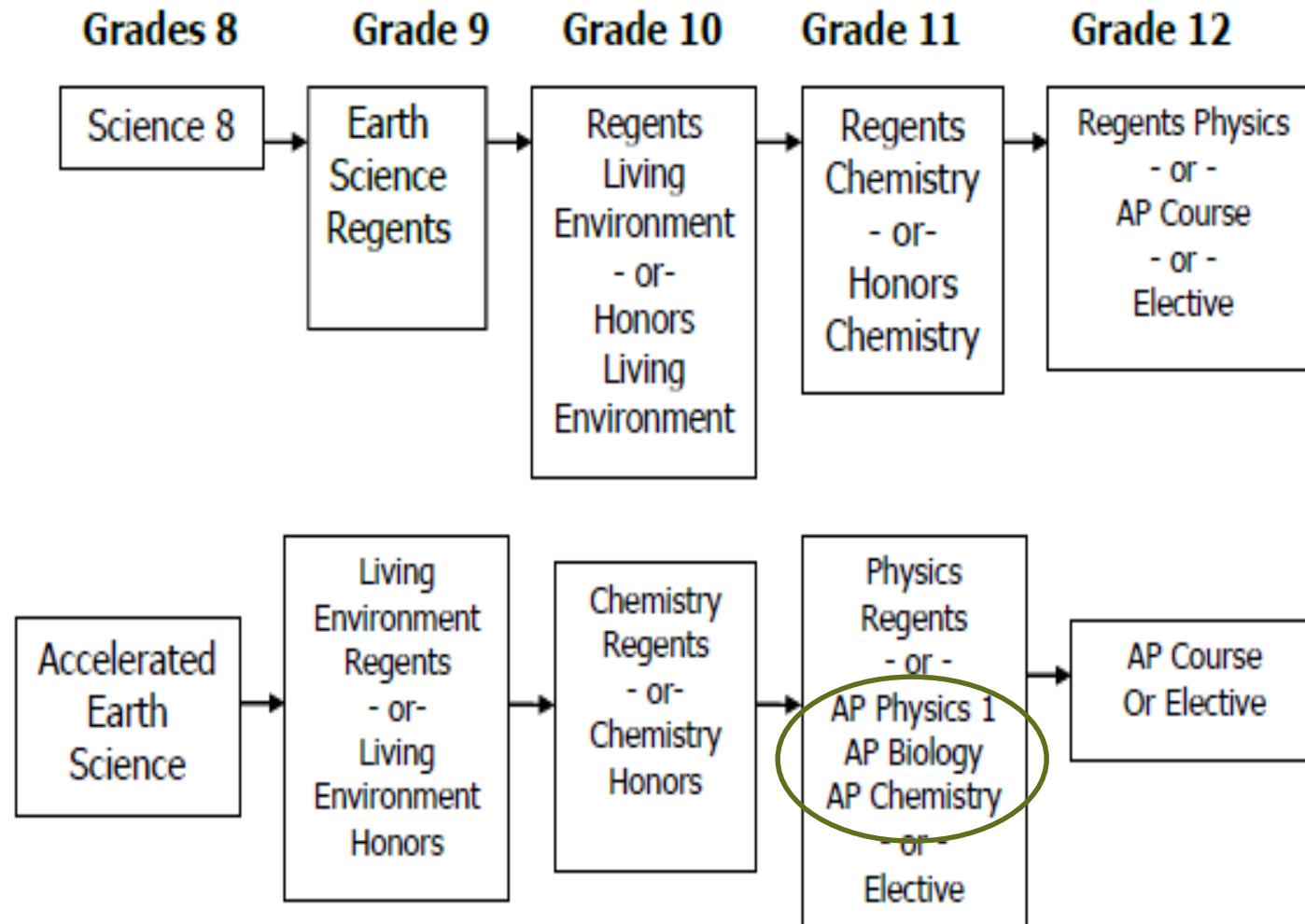

Art Department Flow Chart: Grades 7-12

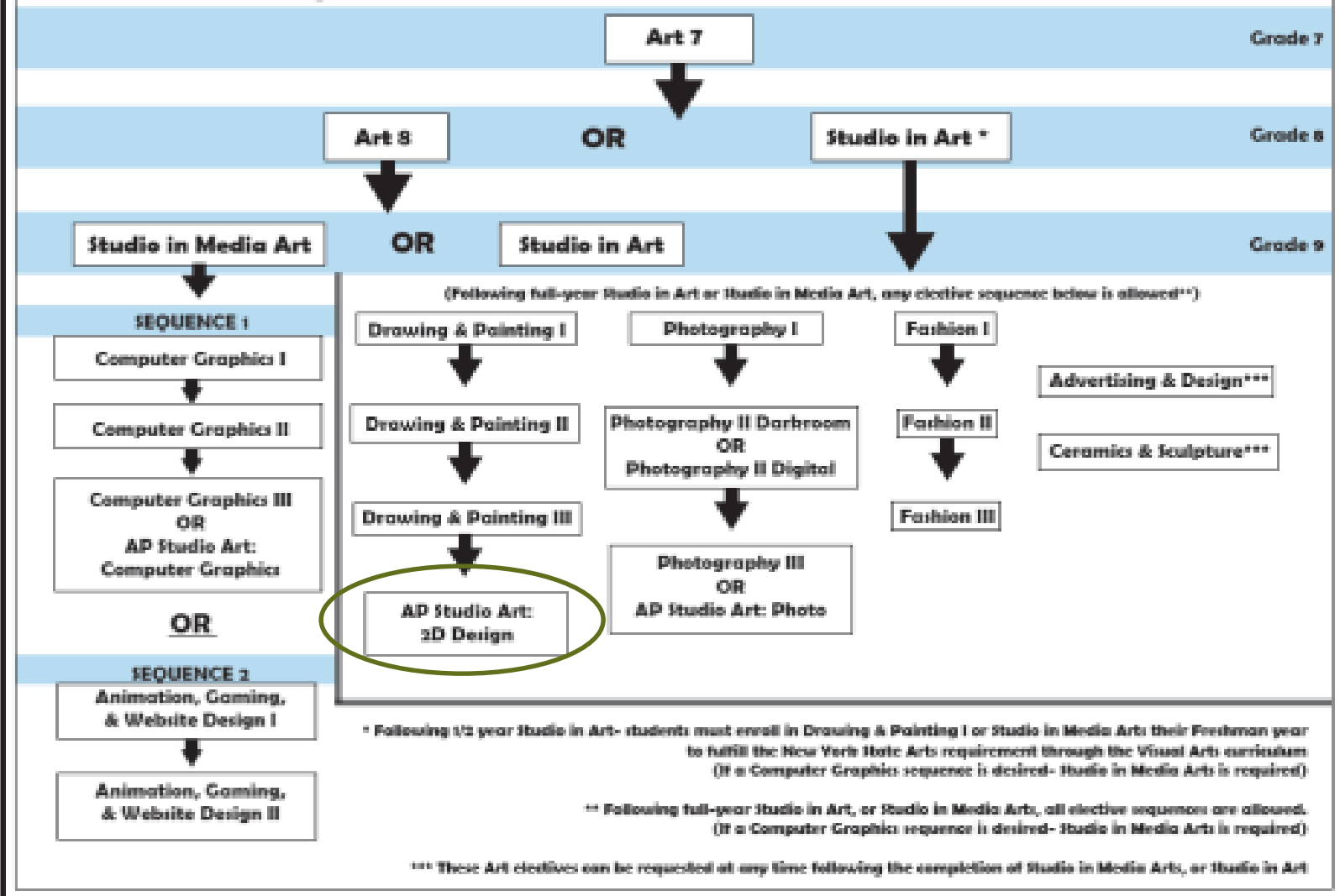

Traditional Schedule

	Term Q1 (09/09/15- 11/13/15)	Term Q2 (11/16/15- 02/01/16)	Term Q3 (02/02/16- 04/07/16)	Term Q4 (04/08/16- 06/24/16)
Zero	EMPTY	EMPTY	EMPTY	EMPTY
MAP	998-67 MIDDLE SCHOOL ADVISORY PROGRAM Curran, D. Rm: C27	998-67 MIDDLE SCHOOL ADVISORY PROGRAM Curran, D. Rm: C27	998-67 MIDDLE SCHOOL ADVISORY PROGRAM Curran, D. Rm: C27	998-67 MIDDLE SCHOOL ADVISORY PROGRAM Curran, D. Rm: C27
1	812-3 ENGLISH 8 Ninivaggi, P. Rm: D6 Team: 8A	812-3 ENGLISH 8 Ninivaggi, P. Rm: D6 Team: 8A	812-3 ENGLISH 8 Ninivaggi, P. Rm: D6 Team: 8A	812-3 ENGLISH 8 Ninivaggi, P. Rm: D6 Team: 8A
2	822-4 MATH 8 Milone/Arnow Rm: C24	822-4 MATH 8 Milone/Arnow Rm: C24	822-4 MATH 8 Milone/Arnow Rm: C24	822-4 MATH 8 Milone/Arnow Rm: C24
3	805-3 (1, 3, 5) PHYS ED 8 Salerno, K. Rm: GYM <hr/> 843-1 (2, 4, 6) HEALTH 8 Ferreira, K. Rm: D32	805-3 (1, 3, 5) PHYS ED 8 Salerno, K. Rm: GYM <hr/> 843-1 (2, 4, 6) HEALTH 8 Ferreira, K. Rm: D32	805-3 (1, 3, 5) PHYS ED 8 Salerno, K. Rm: GYM <hr/> 843-1 (2, 4, 6) HEALTH 8 Ferreira, K. Rm: D32	805-3 (1, 3, 5) PHYS ED 8 Salerno, K. Rm: GYM <hr/> 843-1 (2, 4, 6) HEALTH 8 Ferreira, K. Rm: D32
4	806-1 LUNCH 8 Rm: CAFE	806-1 LUNCH 8 Rm: CAFE	806-1 LUNCH 8 Rm: CAFE	806-1 LUNCH 8 Rm: CAFE
5	850-7 SPANISH 1R Schaefer, M. Rm: D26	850-7 SPANISH 1R Schaefer, M. Rm: D26	850-7 SPANISH 1R Schaefer, M. Rm: D26	850-7 SPANISH 1R Schaefer, M. Rm: D26
6	840-4 SCIENCE 8 Gonzalez, Y. Rm: C3	840-4 SCIENCE 8 Gonzalez, Y. Rm: C3	840-4 SCIENCE 8 Gonzalez, Y. Rm: C3	840-4 SCIENCE 8 Gonzalez, Y. Rm: C3
7	830-6 SOC STUDIES 8 Maiello, J. Rm: C30	830-6 SOC STUDIES 8 Maiello, J. Rm: C30	830-6 SOC STUDIES 8 Maiello, J. Rm: C30	830-6 SOC STUDIES 8 Maiello, J. Rm: C30
8	802-1 (1, 3, 5) ART 8 Psillos, S. Rm: C5 <hr/> 803-1 (2, 4, 6) TECHNOLOGY 8 Olitsky, D. Rm: TECA Start: 09/10/2015	802-1 (1, 3, 5) ART 8 Psillos, S. Rm: C5 <hr/> 803-1 (2, 4, 6) TECHNOLOGY 8 Olitsky, D. Rm: TECA	802-1 (1, 3, 5) ART 8 Psillos, S. Rm: C5 <hr/> 803-1 (2, 4, 6) TECHNOLOGY 8 Olitsky, D. Rm: TECA	802-1 (1, 3, 5) ART 8 Psillos, S. Rm: C5 <hr/> 803-1 (2, 4, 6) TECHNOLOGY 8 Olitsky, D. Rm: TECA

Algebra 1 and Earth Science

	Term Q1 (09/09/15- 11/13/15)	Term Q2 (11/16/15- 02/01/16)	Term Q3 (02/02/16- 04/07/16)	Term Q4 (04/08/16- 06/24/16)
Zero	EMPTY	EMPTY	EMPTY	EMPTY
MAP	998-67 MIDDLE SCHOOL ADVISORY PROGRAM Curran, D. Rm: C27	998-67 MIDDLE SCHOOL ADVISORY PROGRAM Curran, D. Rm: C27	998-67 MIDDLE SCHOOL ADVISORY PROGRAM Curran, D. Rm: C27	998-67 MIDDLE SCHOOL ADVISORY PROGRAM Curran, D. Rm: C27
1	301-2 ALGEBRA I Milone, E. Rm: C24	301-2 ALGEBRA I Milone, E. Rm: C24	301-2 ALGEBRA I Milone, E. Rm: C24	301-2 ALGEBRA I Milone, E. Rm: C24
2	850-6 SPANISH 1R Schaefer, M. Rm: D26	850-6 SPANISH 1R Schaefer, M. Rm: D26	850-6 SPANISH 1R Schaefer, M. Rm: D26	850-6 SPANISH 1R Schaefer, M. Rm: D26
3	830-7 SOC STUDIES 8 Antonietto/Arnow Rm: C32	830-7 SOC STUDIES 8 Antonietto/Arnow Rm: C32	830-7 SOC STUDIES 8 Antonietto/Arnow Rm: C32	830-7 SOC STUDIES 8 Antonietto/Arnow Rm: C32
4	806-1 LUNCH 8 Rm: CAFE	806-1 LUNCH 8 Rm: CAFE	806-1 LUNCH 8 Rm: CAFE	806-1 LUNCH 8 Rm: CAFE
5	802-1-3 (1, 3, 5) ART 8 ES Goscinski, M. Rm: C6	802-1-3 (1, 3, 5) ART 8 ES Goscinski, M. Rm: C6	941-3 (1, 3, 5) TECHNOLOGY 8 ES Courtesis, L. Rm: TECC	941-3 (1, 3, 5) TECHNOLOGY 8 ES Courtesis, L. Rm: TECC
	844-3 (2, 4, 6) HEALTH 8 ES Miller, J. Rm: C23	844-3 (2, 4, 6) HEALTH 8 ES Miller, J. Rm: C23	844-3 (2, 4, 6) HEALTH 8 ES Miller, J. Rm: C23	844-3 (2, 4, 6) HEALTH 8 ES Miller, J. Rm: C23
6	812-7 ENGLISH 8 Ninivaggi, P. Rm: D6 Team: 8A	812-7 ENGLISH 8 Ninivaggi, P. Rm: D6 Team: 8A	812-7 ENGLISH 8 Ninivaggi, P. Rm: D6 Team: 8A	812-7 ENGLISH 8 Ninivaggi, P. Rm: D6 Team: 8A
7	807-4 (1, 3, 5) PHYS ED 8 ES Salerno, K. Rm: GYM	807-4 (1, 3, 5) PHYS ED 8 ES Salerno, K. Rm: GYM	807-4 (1, 3, 5) PHYS ED 8 ES Salerno, K. Rm: GYM	807-4 (1, 3, 5) PHYS ED 8 ES Salerno, K. Rm: GYM
	403-2-2 (2, 4, 6) EARTH SCI-R-LAB Menchel, J. Rm: C1 Team: 8A	403-2-2 (2, 4, 6) EARTH SCI-R-LAB Menchel, J. Rm: C1 Team: 8A	403-2-2 (2, 4, 6) EARTH SCI-R-LAB Menchel, J. Rm: C1 Team: 8A	403-2-2 (2, 4, 6) EARTH SCI-R-LAB Menchel, J. Rm: C1 Team: 8A
8	403-1-2 EARTH SCI-R+LAB Menchel, J. Rm: C1 Team: 8A	403-1-2 EARTH SCI-R+LAB Menchel, J. Rm: C1 Team: 8A	403-1-2 EARTH SCI-R+LAB Menchel, J. Rm: C1 Team: 8A	403-1-2 EARTH SCI-R+LAB Menchel, J. Rm: C1 Team: 8A
9	766-1 STRING ORCH 6/7/8 Lucas, E. Rm: ORCH	766-1 STRING ORCH 6/7/8 Lucas, E. Rm: ORCH	766-1 STRING ORCH 6/7/8 Lucas, E. Rm: ORCH	766-1 STRING ORCH 6/7/8 Lucas, E. Rm: ORCH

Earth Science and Studio Art

	Term Q1 (09/09/15- 11/13/15)	Term Q2 (11/16/15- 02/01/16)	Term Q3 (02/02/16- 04/07/16)	Term Q4 (04/08/16- 06/24/16)
Zero	EMPTY	EMPTY	EMPTY	EMPTY
MAP	997-49 MIDDLE SCHOOL ADVISORY PROGRAM Krowles, C. Rm: B29	997-49 MIDDLE SCHOOL ADVISORY PROGRAM Krowles, C. Rm: B29	997-49 MIDDLE SCHOOL ADVISORY PROGRAM Krowles, C. Rm: B29	997-49 MIDDLE SCHOOL ADVISORY PROGRAM Krowles, C. Rm: B29
1	850-5 SPANISH 1R Yanch, K. Rm: D25	850-5 SPANISH 1R Yanch, K. Rm: D25	850-5 SPANISH 1R Yanch, K. Rm: D25	850-5 SPANISH 1R Yanch, K. Rm: D25
2	403-1-5 EARTH SCI-R+LAB Menchel, J. Rm: C1 Team: 8A	403-1-5 EARTH SCI-R+LAB Menchel, J. Rm: C1 Team: 8A	403-1-5 EARTH SCI-R+LAB Menchel, J. Rm: C1 Team: 8A	403-1-5 EARTH SCI-R+LAB Menchel, J. Rm: C1 Team: 8A
3	403-2-5 (1, 3, 5) EARTH SCI-R-LAB Menchel, J. Rm: C1 Team: 8A <hr/> 903-2 (2, 4, 6) STUDIO ART 9 HY Psillos, S. Rm: C5	403-2-5 (1, 3, 5) EARTH SCI-R-LAB Menchel, J. Rm: C1 Team: 8A <hr/> 903-2 (2, 4, 6) STUDIO ART 9 HY Psillos, S. Rm: C5	403-2-5 (1, 3, 5) EARTH SCI-R-LAB Menchel, J. Rm: C1 Team: 8A <hr/> 903-2 (2, 4, 6) STUDIO ART 9 HY Psillos, S. Rm: C5	403-2-5 (1, 3, 5) EARTH SCI-R-LAB Menchel, J. Rm: C1 Team: 8A <hr/> 903-2 (2, 4, 6) STUDIO ART 9 HY Psillos, S. Rm: C5
4	806-1 LUNCH 8 Rm: CAFE	806-1 LUNCH 8 Rm: CAFE	806-1 LUNCH 8 Rm: CAFE	806-1 LUNCH 8 Rm: CAFE
5	830-4 SOC STUDIES 8 Sgroi, S. Rm: C32	830-4 SOC STUDIES 8 Sgroi, S. Rm: C32	830-4 SOC STUDIES 8 Sgroi, S. Rm: C32	830-4 SOC STUDIES 8 Sgroi, S. Rm: C32
6	301-1 ALGEBRA I Milone, E. Rm: C24	301-1 ALGEBRA I Milone, E. Rm: C24	301-1 ALGEBRA I Milone, E. Rm: C24	301-1 ALGEBRA I Milone, E. Rm: C24
7	843-3 (1, 3, 5) HEALTH 8 Miller, J. Rm: C23 <hr/> 805-1 (2, 4, 6) PHYS ED 8 Brooks, E. Rm: GYM	843-3 (1, 3, 5) HEALTH 8 Miller, J. Rm: C23 <hr/> 805-1 (2, 4, 6) PHYS ED 8 Brooks, E. Rm: GYM	843-3 (1, 3, 5) HEALTH 8 Miller, J. Rm: C23 <hr/> 805-1 (2, 4, 6) PHYS ED 8 Brooks, E. Rm: GYM	843-3 (1, 3, 5) HEALTH 8 Miller, J. Rm: C23 <hr/> 805-1 (2, 4, 6) PHYS ED 8 Brooks, E. Rm: GYM
8	812-2 ENGLISH 8 Ninivaggi/Arnow Rm: D6 Team: 8A	812-2 ENGLISH 8 Ninivaggi/Arnow Rm: D6 Team: 8A	812-2 ENGLISH 8 Ninivaggi/Arnow Rm: D6 Team: 8A	812-2 ENGLISH 8 Ninivaggi/Arnow Rm: D6 Team: 8A
9	766-1 STRING ORCH 6/7/8 Lucas, E. Rm: ORCH	766-1 STRING ORCH 6/7/8 Lucas, E. Rm: ORCH	766-1 STRING ORCH 6/7/8 Lucas, E. Rm: ORCH	766-1 STRING ORCH 6/7/8 Lucas, E. Rm: ORCH
10	EMPTY	EMPTY	EMPTY	EMPTY

Resource Room

	Term Q1 (09/09/15- 11/13/15)	Term Q2 (11/16/15- 02/01/16)	Term Q3 (02/02/16- 04/07/16)	Term Q4 (04/08/16- 06/24/16)
Zero	1004-4 (2) ZERO PERIOD AIS MATH Milone, E. Rm: C24	1004-4 (2) ZERO PERIOD AIS MATH Milone, E. Rm: C24	1004-4 (2) ZERO PERIOD AIS MATH Milone, E. Rm: C24	1004-4 (2) ZERO PERIOD AIS MATH Milone, E. Rm: C24
MAP	998-68 MIDDLE SCHOOL ADVISORY PROGRAM Selletti, C. Rm: D30	998-68 MIDDLE SCHOOL ADVISORY PROGRAM Selletti, C. Rm: D30	998-68 MIDDLE SCHOOL ADVISORY PROGRAM Selletti, C. Rm: D30	998-68 MIDDLE SCHOOL ADVISORY PROGRAM Selletti, C. Rm: D30
1	850-5 SPANISH 1R Yanch, K. Rm: D25	850-5 SPANISH 1R Yanch, K. Rm: D25	850-5 SPANISH 1R Yanch, K. Rm: D25	850-5 SPANISH 1R Yanch, K. Rm: D25
2	830-5 SOC STUDIES 8 Antoniello, R. Rm: C32	830-5 SOC STUDIES 8 Antoniello, R. Rm: C32	830-5 SOC STUDIES 8 Antoniello, R. Rm: C32	830-5 SOC STUDIES 8 Antoniello, R. Rm: C32
3	880-3 RESOURCE ROOM 8 Mento, C. Rm: C28	880-3 RESOURCE ROOM 8 Mento, C. Rm: C28	880-3 RESOURCE ROOM 8 Mento, C. Rm: C28	880-3 RESOURCE ROOM 8 Mento, C. Rm: C28
4	806-1 LUNCH 8 Rm: CAFE	806-1 LUNCH 8 Rm: CAFE	806-1 LUNCH 8 Rm: CAFE	806-1 LUNCH 8 Rm: CAFE
5	822-5 MATH 8 Baccoli, D. Rm: C22	822-5 MATH 8 Baccoli, D. Rm: C22	822-5 MATH 8 Baccoli, D. Rm: C22	822-5 MATH 8 Baccoli, D. Rm: C22
6	812-7 ENGLISH 8 Ninivaggi, P. Rm: D6 Team: 8A	812-7 ENGLISH 8 Ninivaggi, P. Rm: D6 Team: 8A	812-7 ENGLISH 8 Ninivaggi, P. Rm: D6 Team: 8A	812-7 ENGLISH 8 Ninivaggi, P. Rm: D6 Team: 8A
7	807-4 (1, 3, 5) PHYS ED 8 ES Salerno, K. Rm: GYM <hr/> 844-5 (2, 4, 6) HEALTH 8 ES Miller, J. Rm: C23	807-4 (1, 3, 5) PHYS ED 8 ES Salerno, K. Rm: GYM <hr/> 844-5 (2, 4, 6) HEALTH 8 ES Miller, J. Rm: C23	807-4 (1, 3, 5) PHYS ED 8 ES Salerno, K. Rm: GYM <hr/> 844-5 (2, 4, 6) HEALTH 8 ES Miller, J. Rm: C23	807-4 (1, 3, 5) PHYS ED 8 ES Salerno, K. Rm: GYM <hr/> 844-5 (2, 4, 6) HEALTH 8 ES Miller, J. Rm: C23
8	840-3 SCIENCE 8 Ward, J. Rm: D1	840-3 SCIENCE 8 Ward, J. Rm: D1	840-3 SCIENCE 8 Ward, J. Rm: D1	840-3 SCIENCE 8 Ward, J. Rm: D1

English or Math + Lab

	Term Q1 (09/09/15- 11/13/15)	Term Q2 (11/16/15- 02/01/16)	Term Q3 (02/02/16- 04/07/16)	Term Q4 (04/08/16- 06/24/16)
Zero	1004-4 (2) ZERO PERIOD AIS MATH Milone, E. Rm: C24	1004-4 (2) ZERO PERIOD AIS MATH Milone, E. Rm: C24	1004-4 (2) ZERO PERIOD AIS MATH Milone, E. Rm: C24	1004-4 (2) ZERO PERIOD AIS MATH Milone, E. Rm: C24
MAP	996-26 MIDDLE SCHOOL ADVISORY PROGRAM Maiello, J. Rm: C30	996-26 MIDDLE SCHOOL ADVISORY PROGRAM Maiello, J. Rm: C30	996-26 MIDDLE SCHOOL ADVISORY PROGRAM Maiello, J. Rm: C30	996-26 MIDDLE SCHOOL ADVISORY PROGRAM Maiello, J. Rm: C30
1	830-1 SOC STUDIES 8 Benjamin/Kinstler Rm: C31	830-1 SOC STUDIES 8 Benjamin/Kinstler Rm: C31	830-1 SOC STUDIES 8 Benjamin/Kinstler Rm: C31	830-1 SOC STUDIES 8 Benjamin/Kinstler Rm: C31
2	840-1 SCIENCE 8 Burke/Kinstler Rm: C2 Start: 09/11/2015	840-1 SCIENCE 8 Burke/Kinstler Rm: C2	840-1 SCIENCE 8 Burke/Kinstler Rm: C2	840-1 SCIENCE 8 Burke/Kinstler Rm: C2
3	812-6 ENGLISH 8 Ninivaggi, P. Rm: D6 Team: 8A	812-6 ENGLISH 8 Ninivaggi, P. Rm: D6 Team: 8A	812-6 ENGLISH 8 Ninivaggi, P. Rm: D6 Team: 8A	812-6 ENGLISH 8 Ninivaggi, P. Rm: D6 Team: 8A
4	806-1 LUNCH 8 Rm: CAFE	806-1 LUNCH 8 Rm: CAFE	806-1 LUNCH 8 Rm: CAFE	806-1 LUNCH 8 Rm: CAFE
5	822-5 MATH 8 Baccoli, D. Rm: C22	822-5 MATH 8 Baccoli, D. Rm: C22	822-5 MATH 8 Baccoli, D. Rm: C22	822-5 MATH 8 Baccoli, D. Rm: C22
6	850-3 SPANISH 1R Yanch, K. Rm: D25	850-3 SPANISH 1R Yanch, K. Rm: D25	850-3 SPANISH 1R Yanch, K. Rm: D25	850-3 SPANISH 1R Yanch, K. Rm: D25
7	807-4 (1, 3, 5) PHYS ED 8 ES Salerno, K. Rm: GYM <hr/> 844-5 (2, 4, 6) HEALTH 8 ES Miller, J. Rm: C23	807-4 (1, 3, 5) PHYS ED 8 ES Salerno, K. Rm: GYM <hr/> 844-5 (2, 4, 6) HEALTH 8 ES Miller, J. Rm: C23	807-4 (1, 3, 5) PHYS ED 8 ES Salerno, K. Rm: GYM <hr/> 844-5 (2, 4, 6) HEALTH 8 ES Miller, J. Rm: C23	807-4 (1, 3, 5) PHYS ED 8 ES Salerno, K. Rm: GYM <hr/> 844-5 (2, 4, 6) HEALTH 8 ES Miller, J. Rm: C23
8	802-1 (1, 3, 5) ART 8 Psillos, S. Rm: C5 <hr/> 803-1 (2, 4, 6) TECHNOLOGY 8 Olitsky, D. Rm: TECA	802-1 (1, 3, 5) ART 8 Psillos, S. Rm: C5 <hr/> 803-1 (2, 4, 6) TECHNOLOGY 8 Olitsky, D. Rm: TECA	802-1 (1, 3, 5) ART 8 Psillos, S. Rm: C5 <hr/> 803-1 (2, 4, 6) TECHNOLOGY 8 Olitsky, D. Rm: TECA	802-1 (1, 3, 5) ART 8 Psillos, S. Rm: C5 <hr/> 803-1 (2, 4, 6) TECHNOLOGY 8 Olitsky, D. Rm: TECA

Additional Opportunities Available During Zero Period

Zero Period

- Clubs
- Health 8
- ELA AIS
- Math AIS

Ninth Period

- Remedial (Tuesday, Thursday and Wednesday for special area classes)

Successful 2016/2017 School Year

- Construct a program of courses that is appropriate
- Acceleration in all courses is not always the best option
- Take into account course recommendations prior to Self-Selecting
- Continually monitor the information on the Portal
- Teacher Contact (Phone, E-mail & Team Meetings)
- Join and attend PTA Meetings
- Open door policy
- Encourage the use of remedial whenever possible

Questions and/or Concerns